

The New Årsta Railway Bridge - Sweden

Project Description:

The New Årsta Railway Bridge in Stockholm, Sweden, which is under construction at this very moment, will be opened for traffic in 2006. The bridge is part of the overall upgrading to four tracks, compared to today's two tracks on the old bridge, between Stockholm South and a new station called Årstaberg. The purpose of the extension is to increase track capacity. The structure is a very slender and complex prestressed concrete bridge without any ballast. Therefore, the Swedish National Railway Administration (Banverket) has initiated a measuring program to follow up and evaluate/verify stresses and deformations during construction and operation. Static and dynamic measurements/analyses are being conducted.



Data animation of the New Årsta Railway Bridge

Quick Facts:

- **Name and Location:** The New Årsta Railway Bridge, Stockholm, Sweden
- **Owner:** The Swedish National Railway Administration (Banverket)
- **Structure category:** long span bridge
- **Spans:** 11 spans: 48/ 78/ 78/ 78/ 78/ 78/ 78/ 78/ 78/ 78/ 65 m
- **Structural system:** continuous prestressed concrete troughed-beam bridge
- **Start of SHM:** January, 2003
- **Number of sensors installed:** 86
- **Instrumentation design by:**
 - **Strain gauges:** Royal Institute of Technology (KTH), Department of Civil and Architectural Engineering, Division of Structural Design and Bridges
 - **Fibre optic sensors (SOFO system):** SMARTEC
- **Installations:** Most of the installation work was carried out by The Royal Institute of Technology (KTH) , Department of Civil and Architectural Engineering, Division of Structural Design and Bridges

Description of Structure:

The bridge is 833 m long, 19,5 m wide and has ten piers with an elliptical cross-section measuring 7 x 2,5 m. The pier height varies from 9 to 25 m. The rail carriageway is embedded in a trough with 1,2 m high parapets. Running along the left-hand side of the bridge is a pedestrian and cycle way, and on the eastern side there is a road for service and rescue vehicles. In order to reduce the weight of the bridge structure and to distribute forces the beam height is decreased by eliminating the ballast and embedding the rail fasteners directly in the concrete structure. The superstructure is built in two different ways. On the north side, the curved section of the bridge, use is made of conventional fixed scaffolding, whereas from the south, the straight section of the bridge, launching formwork is used and gradually advanced as each span is completed. The design was first produced by Foster/Aarup, but reworked twice. The final design was done by the Danish consult COWI A/S.

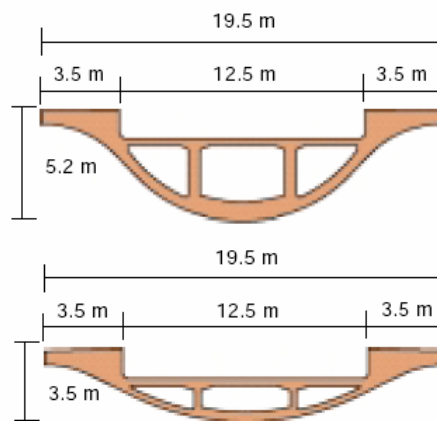

The slender design of the superstructure is thickest above the piers (upper figure) and tapers of towards the center of the span (lower figure)

Purpose of Inspection:

The aim is to verify uncertainties in the structure during construction and 10 years of service, leading to knowledge and perhaps updated codes, especially concerning dynamic effects. This will, in turn, give economical and safe solutions concerning similar structures in the future.

Static measuring:

- Verify that maximum strains and stresses are kept within permissible limits
- Check that no cracking occurs in critical sections, according to design
- Study changes in strain, both during construction and in service
- Compare results from fibre optic sensors with results from strain gauges

Dynamic measuring:

- Evaluate fundamental frequencies, mode shapes and damping ratios
- Evaluate dynamic effects of trains crossing the bridge, especially train/bridge interaction and effects of track irregularities
- Evaluate long-term changes in the bridge's dynamic properties

Sensor Details:

Type of sensors	Number	Location
Strain gauges	24	The figure below describes the locations
Accelerometers	6	
LVDT	1	
Fibre optic sensors	46	
Thermocouples	9	

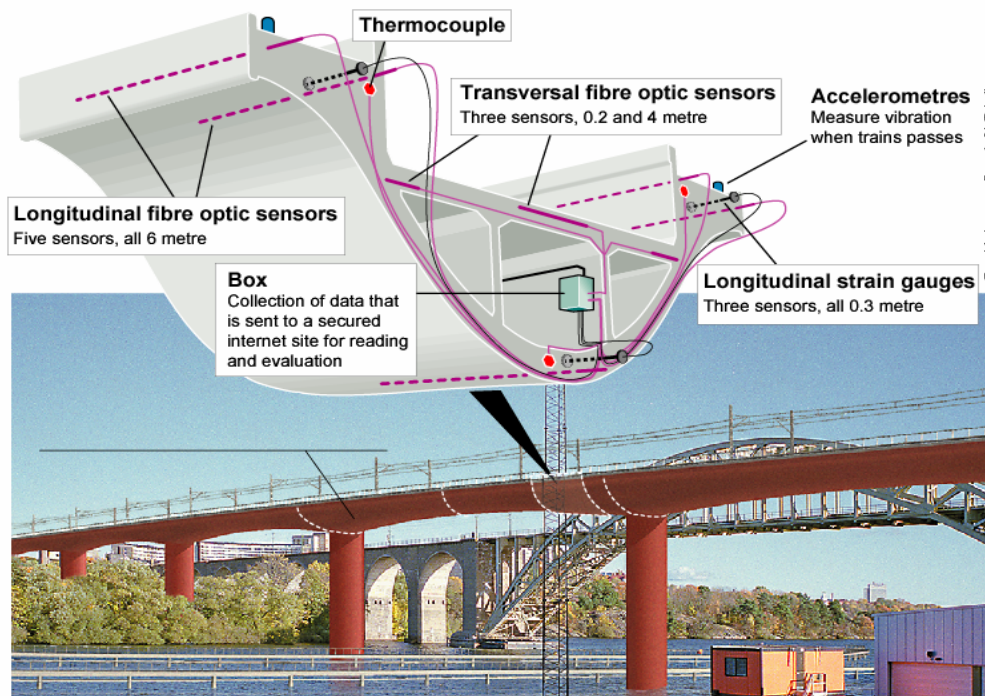

Illustration of one specific cross-section with sensors measuring strain, temperature and acceleration

Measurement Equipment and Data Management:

Type of system	Data Management	CMS
PC based measurement system	<ul style="list-style-type: none"> ▪ data pre-analysis (statistics) on site ▪ main analysis, graphical presentation and documentation in office ▪ data transfer via broadband ▪ long term data base 	?

Examples of Outcomes:

Only some early results are presented here and much more will be presented in a short time since more data acquisition and analysis work in the office has to be carried out before any further conclusions can be drawn.

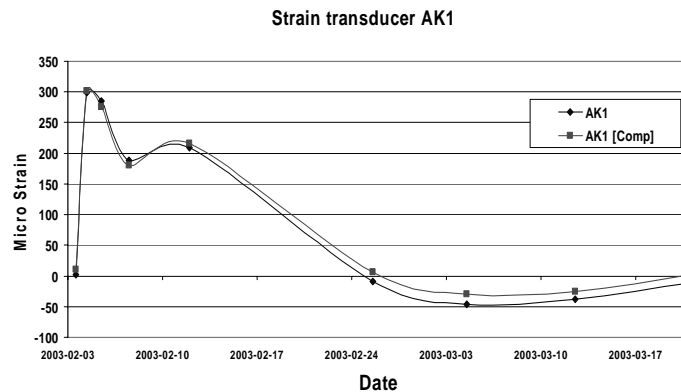

Typical results from strain transducers during construction (casting).
One of the curves is temperature compensated.

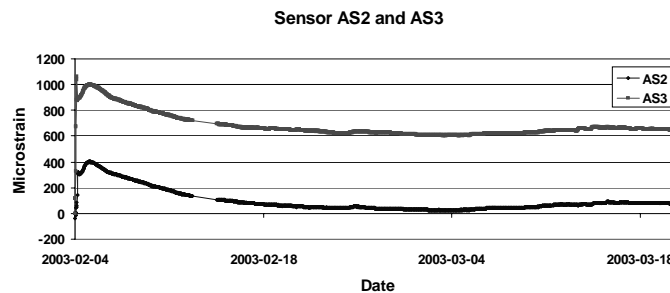

Results from two different fibre optic sensors in a very early stage.

Benefits of using SHM Technologies in the Project:

Since measurements are planned for the first 10 years of service it will be possible to, for example, detect long-term changes in the bridge's dynamic properties.

References:

- M. Enckell-Ei Jemli, R. Karoumi, J. Wiberg, "Structural health monitoring for an optimised prestressed concrete bridge", Proceedings of **SHMII 2003**, Nov 13-15, 2003, Tokyo, Japan
- M. Enckell-Ei Jemli, R. Karoumi, F. Lanaro, "Monitoring of the New Årsta Railway Bridge using traditional and fibre optic sensors", SPIE's Symposium on Smart Structures and Materials, NDE for Health Monitoring & Diagnostics, March 2-6, 2003, San Diego, California, USA
- Swedish National Railway Administrator (Banverket), Eastern Track Region, "The new Årsta Bridge – a new railway bridge in Stockholm"
- Ny Teknik, "Ingjutna sensorer håller koll på ny järnvägsbro" (In Swedish), May, 2003

Submitted by:

Ph.D. Student Johan Wiberg
Royal Institute of Technology (KTH)
Department of Civil and Architectural Engineering
Division of Structural Design and Bridges
100 44 Stockholm, Sweden
Phone: +46 8 790 64 93
Fax: +46 8 21 69 49
E-mail: johan.wiberg@byv.kth.se